

ステップ

K-1855

ステンレス製



あおりステップ
GATE STEPS



K-1855-1



K-1855-2

特徴 Feature

- 取付け面からの突起が少ない平面タイプです。
- ステップ収納時はスプリングで押さえていますので振動などで反転しません。
- The flush type which have few projections on the installed surface.
- When the gate step is housed, it is held firmly by the spring, so that it will not turn in reverse even become subject to vibration.

仕様	● 材質：冷間圧延ステンレス鋼板(SUS304) ● 表面仕上：K-1855-1/光沢バレル研磨 K-1855-2/電解研磨
用途	● 特装车・平ボディ・船舶などのステップ
納期	● 標準在庫品

Specifications	● Material: Cold rolled stainless steel plate (SUS304) ● Finish: K-1855-1/Gloss barrel polishing K-1855-2/Electrolytic polishing
Specific-use	● The step of specially equipped vehicles, flat bodies and ships

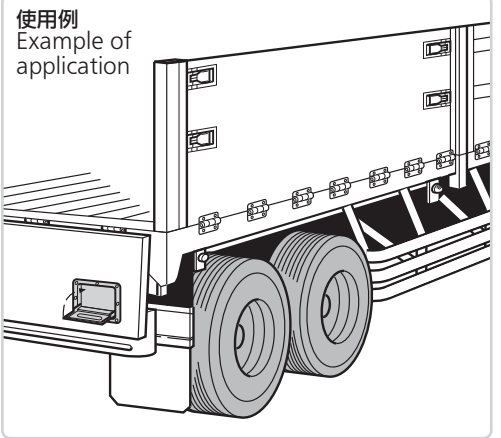

使用例
Example of application

商品番号 Product No.	RoHS 10	製品質量(g) Mass	コード Code
K-1855-1	●	1,685	31096
K-1855-2	●	700	31036

●: RoHS10指令対応品
▲: RoHS10指令に対応可能です。

[K-1855-1]

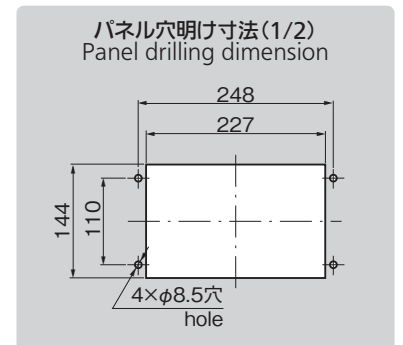
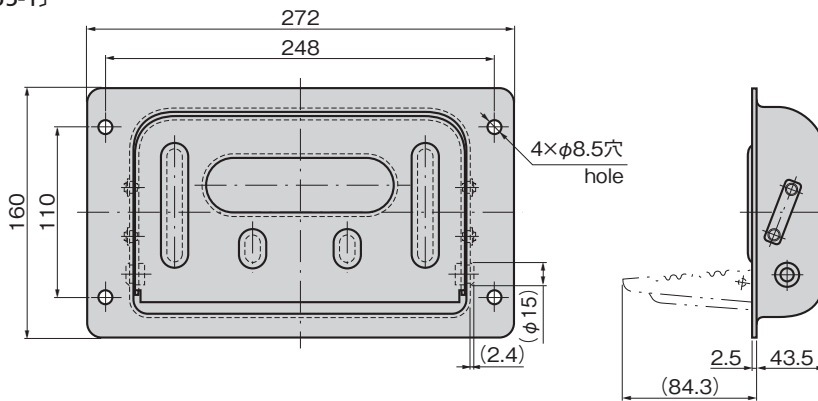

[K-1855-2]

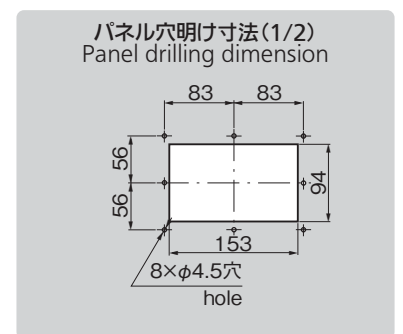
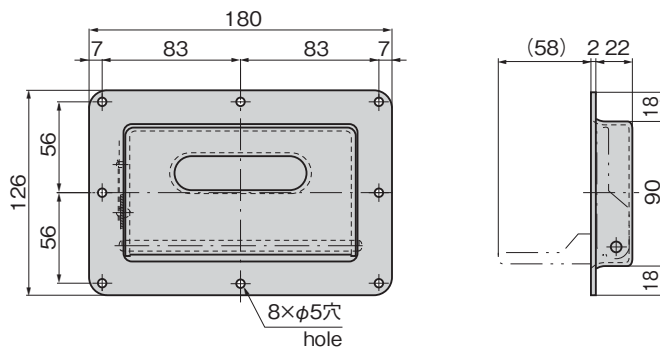

価格確認

