

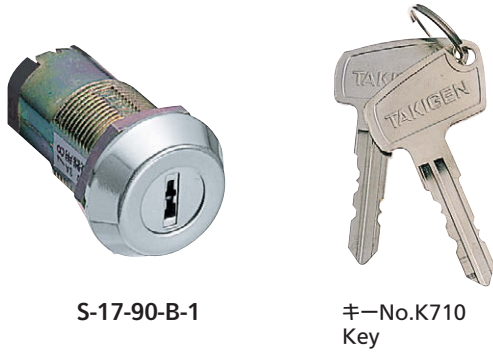

U.L.登録品.: No.: E245410

特徴 Feature

- パネル穴明けはS-8と同寸法です。
- Panel drilling dimensions are same as S-8.



S-17-90-B-1

キーNo.K710  
Key

仕様	<ul style="list-style-type: none"> <li>● 材 質: 本体・シリンダー錠部/亜鉛合金 (ZDC) (本体、ステンレスカバー付) キー/黄銅板 (C2801P)</li> <li>● 表面仕上: 本体/亜鉛めっきクロメート処理 (MZZn-C) キー/ニッケルめっき (MBNi)</li> <li>● 同一鍵番号・鍵違いがあります。</li> <li>● 付 属 品: キー2本</li> </ul>
用途	● 各種電源スイッチ
納期	● 標準在庫品
スイッチ部 特性	<ul style="list-style-type: none"> <li>● 定 格: AC125V・3A (抵抗負荷) DC30V・3A (抵抗負荷)</li> <li>● 最小適用負荷: DC5V・100mA (抵抗負荷)</li> <li>● 接触抵抗: 20mΩ以下 (初期値)</li> <li>● 絶縁抵抗: 100MΩ以上 (500VDC)</li> <li>● 耐 電 圧: (50/60Hz, 1分間) 非連続端子間 AC1000V 各端子と非充電金属部間 AC1500V</li> <li>● 耐 久 性: 機械的3万回以上 電氣的1.5万回以上</li> <li>● 接点材料: 銀めっき</li> <li>● 使用周囲温度: -20~+70°C (氷結しないこと)</li> <li>● 使用周囲湿度: 85%RH以下 (結露しないこと)</li> <li>● 耐 振 動: 10~55Hz 複振幅1.5mm</li> <li>● 耐 衝 撃: 30G以上</li> </ul>
備考	<ul style="list-style-type: none"> <li>● U.L. 認定品は1回路のみとなります。</li> <li>● 微小負荷タイプはお問合せください。</li> <li>● 鍵違いも製作します。</li> </ul>

CONTROL KEYSWITCHES  
コントロール  
キースイッチ  
ソレノイド付  
キースイッチ  
オペレーター  
キースイッチ  
止め金付  
キースイッチ  
マイクロ  
スイッチ

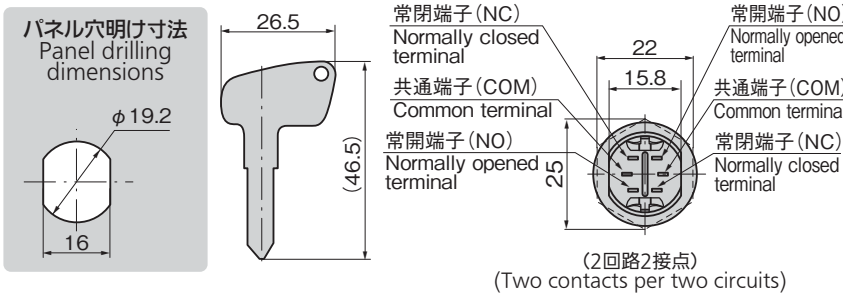
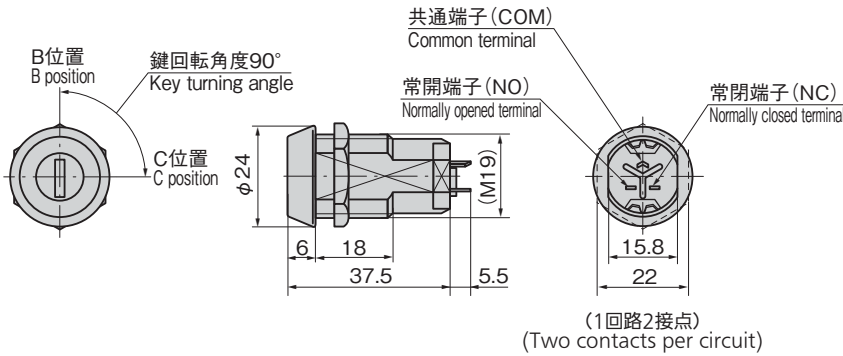

Specifi- cations	<ul style="list-style-type: none"> <li>● Material: Main body and lock: Zinc alloy (ZDC) (Main body with stainless steel cover) Key: Brass plate (C2801P)</li> <li>● Finish: Main body: Zinc plating chromate treatment (MZZn-C) Key: Nickel plating (MBNi)</li> <li>● Keyed alike and key differences are available.</li> <li>● Accessories: Two keys</li> </ul>
Specific use	<ul style="list-style-type: none"> <li>● Various power switches</li> <li>● Rated: AC125V 3A (resistance load) DC30V 3A (resistance load) Min. applicable load: DC5V 100mA (resistance load)</li> <li>● Contact resistance: 20mΩ or less</li> <li>● Insulation resistance: 100MΩ or more (500VDC)</li> <li>● Withstand voltage: (50/60 Hz, one minute) Between non-continuous terminals: AC1000V Between each terminal and non-charged metal: AC1500V</li> <li>● Durability: Mechanical: 30,000 time or more Electrical: 15,000 time or more</li> <li>● Contact material: Silver plating</li> <li>● Ambient temperature: -20°C to +70°C (non-freezing)</li> <li>● Operating humidity range: 85%RH or less (non-condensing)</li> <li>● Vibration resistance: 10 to 55Hz multiple-amplitude 1.5mm</li> <li>● Impact resistance: 30G or more</li> <li>● U.L. approved items are one-circuit only.</li> </ul>
Switch charac- teristic	
Remarks	

接点構成表 Contact structures table

●印の位置は鍵が抜き差しできます。  
Position of mark (●) shows that key can be inserted/removed.

商品番号 Product No.	U.L. 認定品 U.L. approved	鍵回転角度 Key turning angle	B 位置 B position	C 位置 C position
S-17-90-B-1 (1回路2接点型) (one-circuit-two-contact type)	●	90°	● SW COM NO NC	● SW COM NO NC
S-17-90-BC-1 (1回路2接点型) (one-circuit-two-contact type)	●	90°	● SW COM NO NC	● SW COM NO NC
S-17-90-B-2 (2回路2接点型) (two-circuit-two-contact type)	×	90°	● SW1 COM NO NC SW2 COM NO NC	● SW1 COM NO NC SW2 COM NO NC
S-17-90-BC-2 (2回路2接点型) (two-circuit-two-contact type)	×	90°	● SW1 COM NO NC SW2 COM NO NC	● SW1 COM NO NC SW2 COM NO NC

商品番号 Product No.	RoHS 10+	製品質量 (g) Mass	コード Code
S-17-90-B-1同番 Keyed alike	●	60	40148
S-17-90-B-2同番 Keyed alike	●	60	40207
S-17-90-BC-1同番 Keyed alike	●	60	40150
S-17-90-BC-2同番 Keyed alike	●	60	40209

●: RoHS10指令対応品  
▲: RoHS10指令に対応可能です。



価格確認