

特徴 Feature

- ソレノイドロックの交流タイプ
- ラッチ機構(自動施錠タイプ)
- 遠隔操作で解錠できます。
- 表面・裏面取付け両用(表面取付け時はカバーを外して行ってください。)
- 通電していないときでも解錠できる非常解錠用錠前付です。(LE-60-E・ES)
- 施解錠が信号によって確認できます。(LE-60-S・ES)

- The AC type of the solenoid lock.
- The latch mechanism is incorporated. (auto-locking type)
- Can be operated with a remote control.
- Both front and rear surface attachment. (remove the cover when choosing the front surface attachment)
- Equipped with emergency lock release mechanism for unlocking when not energized. (LE-60-E・ES)
- Locking/unlocking can be checked the signal. (LE-60-S・ES)



LE-60-10-ES



LE-60-11



キーNo.T750  
Key

[LE-60-10]

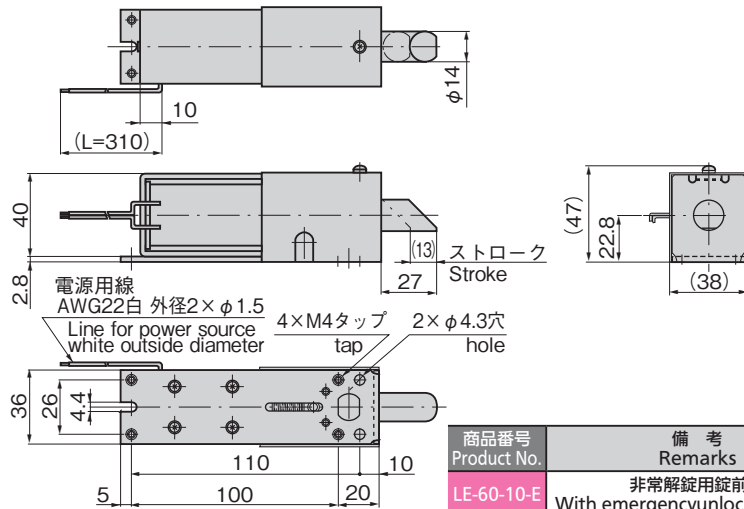

[LE-60-10-E  
LE-60-10-ES  
LE-60-10-S] ※本図はLE-60-ESです。

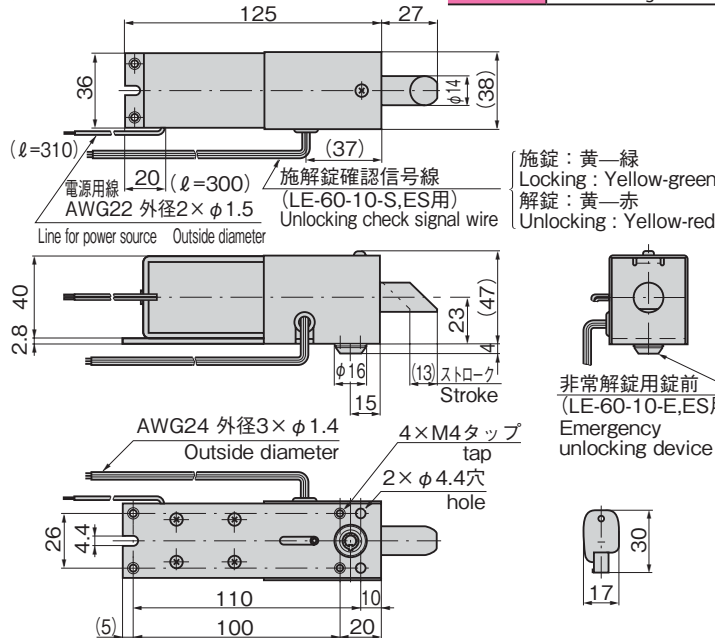

商品番号 Product No.	備考 Remarks
LE-60-10-E	非常解錠用錠前付 With emergencyunlocking device
LE-60-10-S	施解錠確認スイッチ付 Withlocking/unlocking check switch
LE-60-10-ES	非常解錠用錠前、施解錠確認スイッチ付 With emergency unlocking device With locking/unlocking check switch

[LE-60-11]

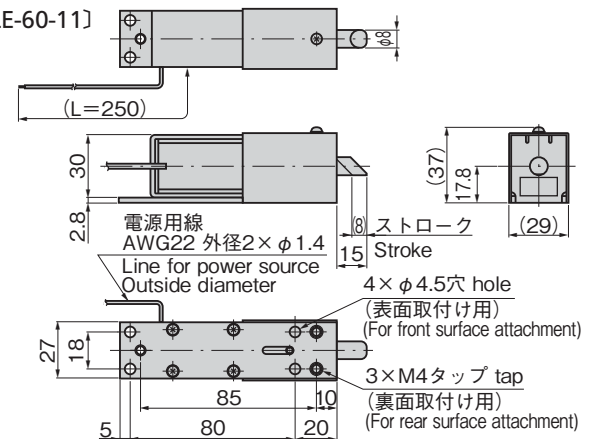

仕様	● 通電率: 100%(連続定格) ● 使用周囲温度: -5~+40℃(氷結しないこと) ● 使用周囲湿度: 85%RH以下(結露しないこと) ● LE-60-10-S・ES用スイッチ定格(抵抗負荷): AC125V・1A, DC30V・0.5A
用途	● パスボックス・各種機器
納期	● 標準在庫品(ESタイプはお問合せください)
備考	● パリスタ内蔵 ● AC100V以外の仕様は特注です。DC24VタイプはLE-30(1493~1495ページ)をご覧ください。 ● 本製品のラッチストローク及び、引込み力、押し出し力は水平取付け時の値です。 ● 周囲温度40℃で、コイル温度上昇分が約65℃となる消費電力を定格電圧(連続定格)としています。 ● ソレノイドに連続通電すると高温(70℃前後)になります。手が触れる懸念がある場合は放熱を考慮の上、火傷防止の処置をしてください。 ● 通電動作時はラッチへの負荷を取除いてください。 ● 施解錠は錠前の構造上、鍵を押しながら回してください。

Specifications	● Duty cycle: 100% (continuous rating) ● Ambient temperature: -5°C to +40°C (non-condensing) ● Operating humidity range: 85%RH or less (non-dewing) ● Verification switch rated (LE-60-10-S/ES) (resistance load): AC125V, 1A/DC30V, 0.5A
Specific use Remarks	● Pass boxes and various cases ● These products are built in varistor. ● The latch stroke, the retraction force and the extension force are value in the horizontal installation. ● The rated voltage (continuous rating) is at a power consumption that causes the temperature of the coil to reach 65°C when the ambient temperature is 40°C. ● When continuously energized, the solenoid becomes hot (around 70°C). If there is a risk of it being touched, measures should be taken to prevent burns with consideration given to heat radiation. ● Remove the load on the latch when operating electrically. ● The construction of the emergency unlocking mechanism requires that the key be pushed in and then turned.

商品番号 Product No.	RoHS 10	定格電圧(連続定格) Rated Voltage (continuous)	消費電力 Power consumption	耐電圧(1分間) Withstand voltage (per minute)	ラッチ引込力(水平時)N Latch retraction force (horizontal)	ラッチ押込力(水平時)N Latch extension force (horizontal)	製品質量(g) Mass	コード Code
LE-60-10		AC100V±5%	9.6W	AC1500V	2.4	3.7	651	50205
LE-60-10-E		AC100V±5%	9.6W	AC1500V	2.4	3.7	652	50206
LE-60-10-S		AC100V±5%	9.6W	AC1500V	2.4	3.7	674	50207
LE-60-10-ES		AC100V±5%	9.6W	AC1500V	2.4	3.7	675	50208
LE-60-11	●	AC100V±5%	6W	AC1500V	1.4	2.1	296	50212

●: RoHS10指令対応品 ▲: RoHS10指令に対応可能です。

