

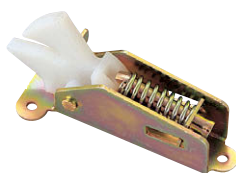

C-850-1



C-850-2



C-850-3

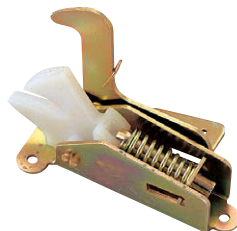

C-850-2S



C-850-4



C-850-5



C-1850-5



C-850-2S 用受金具
Striker

特徴 Feature

- 扉はワンタッチで開閉できます。
- スプリングの作動により強力で扉を保持します。
- The door opens and closes by one touch.
- The door is held securely by the spring action.

[C-850-1・2・3]

仕様

- 材質: 本体/熱間圧延鋼板 (SPHC) フック部/ポリアミド (PA)
- 表面仕上: 亜鉛めっきクロメート処理 (MFZn-C)

[C-850-4]

仕様

- 材質: 本体/熱間圧延鋼板 (SPHC) フック部/ステンレス鋼物 (SUS304)
- 表面仕上: 亜鉛めっきクロメート処理 (MFZn-C)

[C-850-5]

仕様

- 材質: 冷間圧延鋼板 (SPCC)
- 表面仕上: 亜鉛めっきクロメート処理 (MFZn-C)

[C-1850-5]

仕様

- 材質: ステンレス鋼板 (SUS304)
- 表面仕上: パレル研磨

用途

- 特装車・バス・建設機械

納期

- 標準在庫品

備考

- 受金具は別売です。
- 永くご使用いただくために定期的に摺動部に潤滑剤を塗布してください。

[C-850-1・2・3]

Specifi-
cations

- Material: Main unit: Hot rolled steel plate (SPHC) Hook: Polyamide (PA)
- Finish: Zinc plating chromate treatment (MFZn-C)

[C-850-4]

Specifi-
cations

- Material: Main unit: Hot rolled steel plate (SPHC) Hook: Cast stainless steel (SUS304)
- Finish: Zinc plating chromate treatment (MFZn-C)

[C-850-5]

Specifi-
cations

- Material: Cold rolled steel plate (SPCC)
- Finish: Zinc plating chromate treatment (MFZn-C)

[C-1850-5]

Specifi-
cations

- Material: Stainless steel plate (SUS304)
- Finish: Barrel polishing

Specifi-
cations

- Specially equipped vehicles, buses, construction machinery

Remarks

- The striker is optional.
- Apply lubricant to sliding parts regularly for a long life.

[C-850-1]

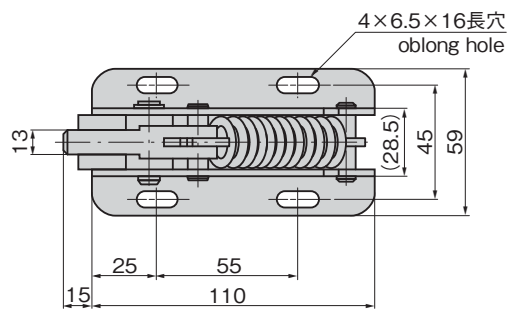

[C-850-2]

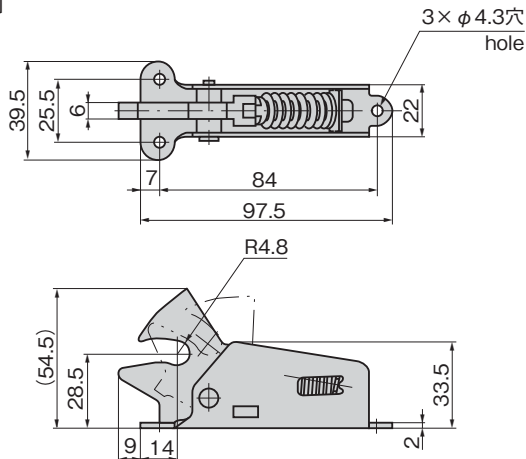

商品番号 Product No.	RoHS 10	引張解放力 N Tension and release force	製品質量 (g) Mass	コード Code
C-850-1		225	385	21368
C-850-2		127	110	21559
C-850-2S		127	190	21560
C-850-2S-Striker 用受金具	●		120	22678
C-850-3	●	93	60	21561
C-850-4		120	190	22982
C-850-5	●	23	30	22193
C-1850-5	●	7.5	30	23551

●: RoHS10指令対応品 ▲: RoHS10指令に対応可能です。

[C-850-3]

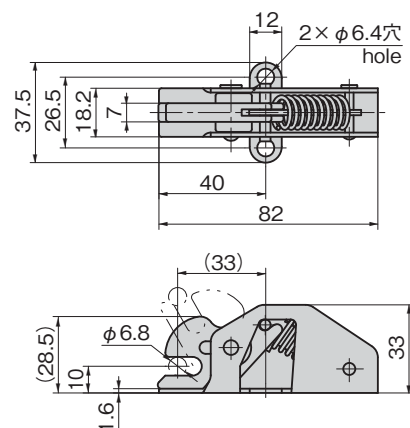

価格確認



[C-850-2S]

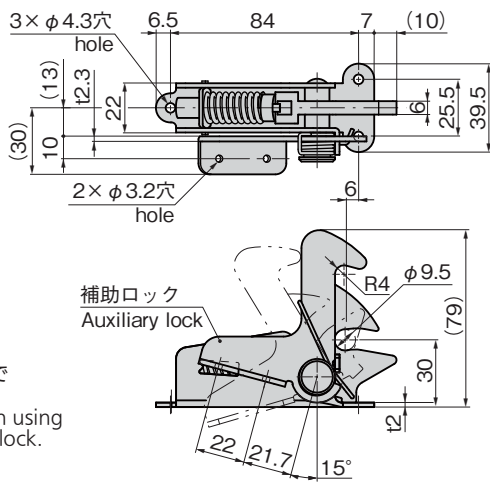

※補助ロック付で
安全設計
 ※Safety design using
the auxiliary lock.

[C-850-5]
 [C-1850-5]

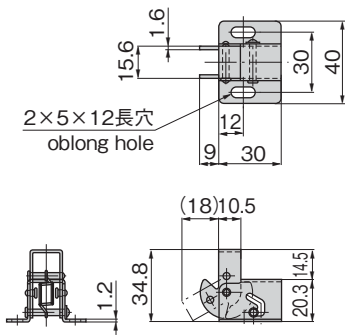

[C-850-4]

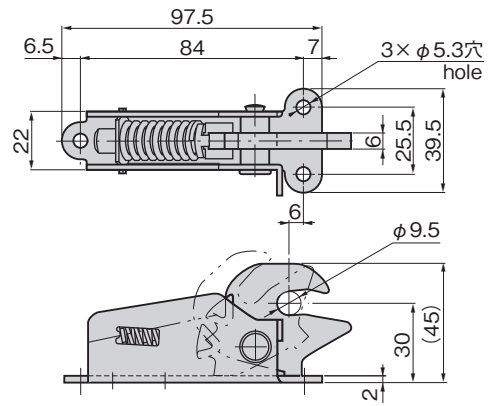

[C-850-2S] 用受金具
Striker

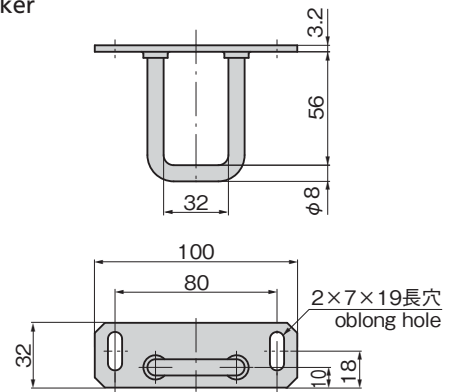

C-850-5取付け例
Example of installation

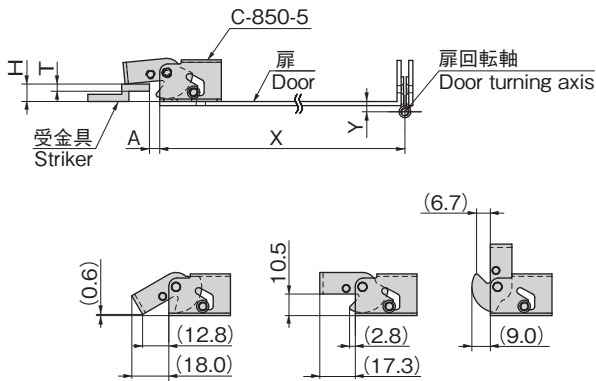

※扉回転軸とC-850-5の取付け関係(X,Y)と受金具の寸法および位置関係(A,H,T)により、扉の開閉時に干渉するためご注意ください。同様に、扉保持力も変動し、扉の誤解錠にも繋がるため、十分な検証も行ってください。
 ※Note that the installed relationship between the door turning axis and C-850-5 (X, Y) as well as the dimensions and positional relationship of the striker (A, H, T) results in contact when opening/closing the door. Similarly, this also affects the door holding force, and sufficient trial and adjustment should be carried out during installation to prevent the door from being able to unlock inadvertently.

作動例
Example of operation

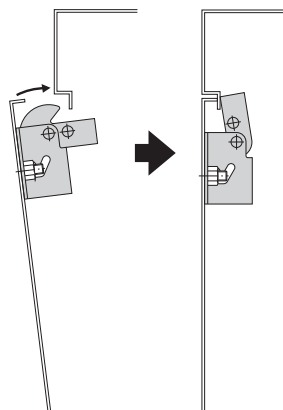

使用例 Example of application

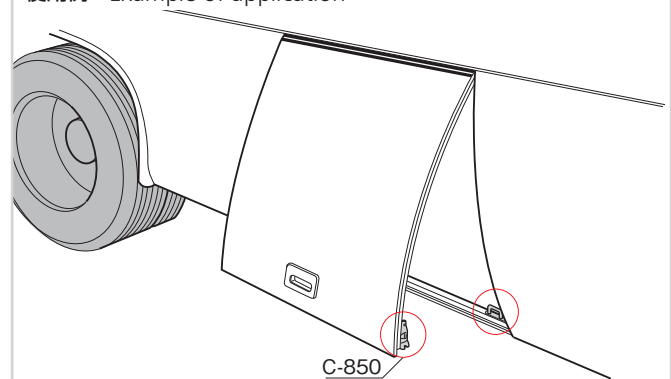

価格確認