



C-1621



C-621-2

[C-1621・C-621]

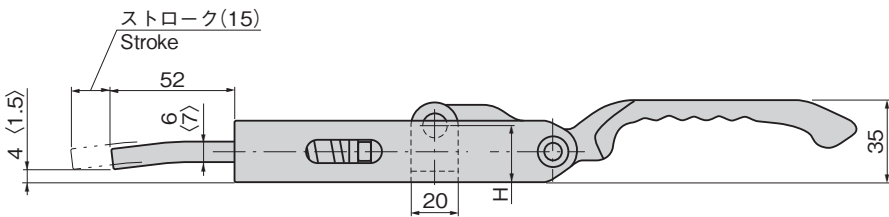
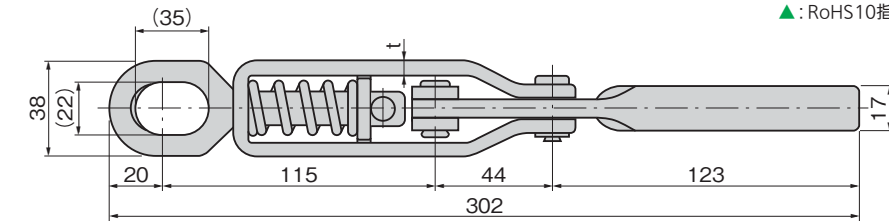

[C-621-2]

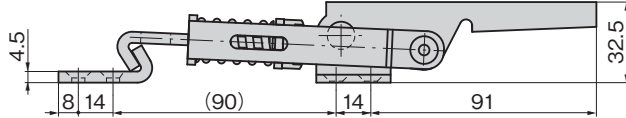
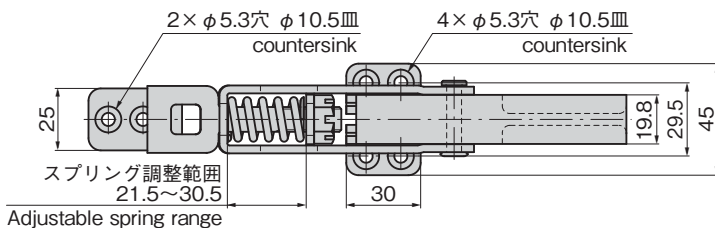

※本図は締代0mmの場合です。
※Drawings show the tightening margin of 0mm.

[C-1621]

- 仕様
- 材質：ステンレス鋼板(SUS304)
 - 表面仕上：バフ研磨

[C-621]

- 仕様
- 材質：熱間圧延鋼板(SPHC)
 - 表面仕上：亜鉛めっきクロメート処理(MFZn-C)
- 納期
- 標準在庫品
- 備考
- 取付けは溶接になります。

[C-1621]

- Specifi-
cations
- Material: Stainless steel plate (SUS304)
 - Finish: Buffing

[C-621]

- Specifi-
cations
- Material: Hot rolled steel plate (SPHC)
 - Finish: Zinc plating chromate treatment (MFZn-C)
- Remarks
- Installation is by welding.

商品番号 Product No.	RoHS 10	H	t	製品質量(g) Mass	コード Code
C-1621		23.5	4	610	22219
C-621		24	4.5	665	21202
C-621-2	●			392	23915

●: RoHS10指令対応品
▲: RoHS10指令に対応可能です。

使用例
Example of application

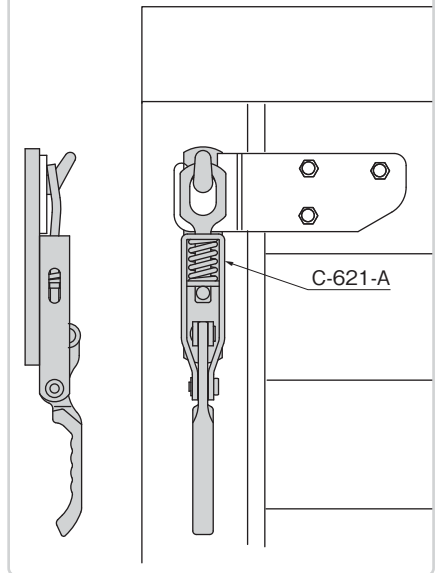

特注品のご案内 Custom-Made Product Information



C-621-A

C-622

C-623