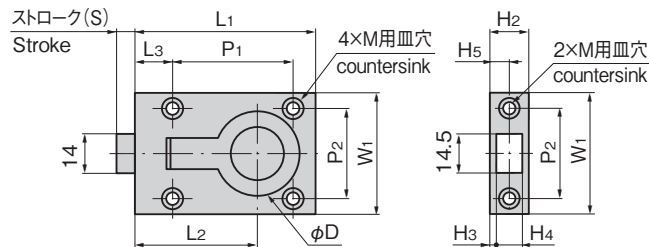
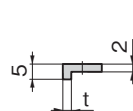
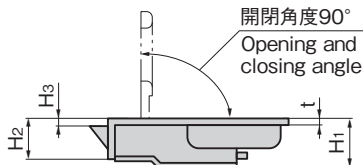
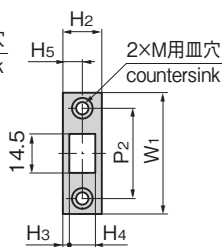
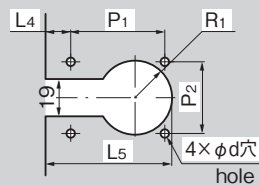
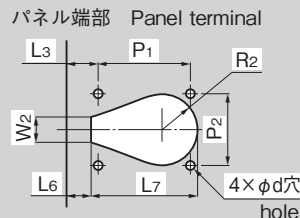
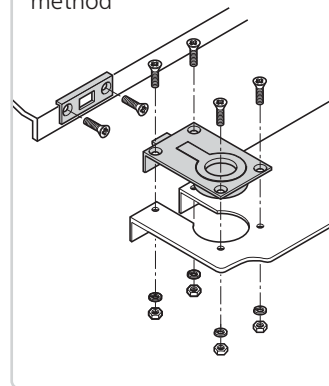

## 特徴 Feature

- リング収納部にパッキンが付いているため、リングを閉める際の音が静かです。(C-42-1-S)
- リングを起こすとラッチが作動し扉が開けられます。閉める場合はワンタッチで閉まります。
- Packing installed in ring pocket, so ring can be replaced quietly (C-42-1-S).
- Putting the lever upright actuates the latch to open the door or cover to close just one-touch push.

仕様	● 材 質 : 亜鉛合金 (ZDC) ● 表面仕上 : クロムめっき (MZCr)
用途	● 配分電盤・木製家具・車両関係の工具箱
納期	● 標準在庫品

Specifications	● Material: Zinc alloy (ZDC) ● Finish: Chrome plating (MZCr)
Specific-use	● Construction machinery, tool boxes or small doors of vehicles.

[本体]  
Main body[受け]  
Catchパネル穴明け寸法 (表付け)  
Panel drilling dimensions  
(Installation on the front)パネル穴明け寸法 (裏付け)  
Panel drilling dimensions  
(Installation on the rear)取付け方法  
Installation  
method

商品番号 Product No.	RoHS 10	L1	L2	L3	L4	L5	L6	L7	W1	W2	H1	H2	H3	H4	H5	R1	R2	P1	P2	D	d	M	t	(S)	製品質量(g) Mass	コード Code
C-42-1	●	68	46	14	12	62	12	51	45	11	19.5	15	3	9	7	18	17	46	34	32	4.2	M4	2	6.5	118	20274
C-42-1-S	●	68	46	14	12	62	12	51	45	11	19.5	15	3	9	7	18	17	46	34	32	4.2	M4	2	6.5	106	24960
C-42-2	●	54	34	10	8.5	48	9	39	35	10	17	11	1.6	7.6	5.5	15.5	14	39	26	26	3.2	M3	1.5	5	62	20275

● : RoHS10指令対応品 ▲ : RoHS10指令に対応可能です。