

C-1150
ステンレス製

C-150
鉄製



スプリングパチン錠
SNAP FASTENERS



C-1150-1

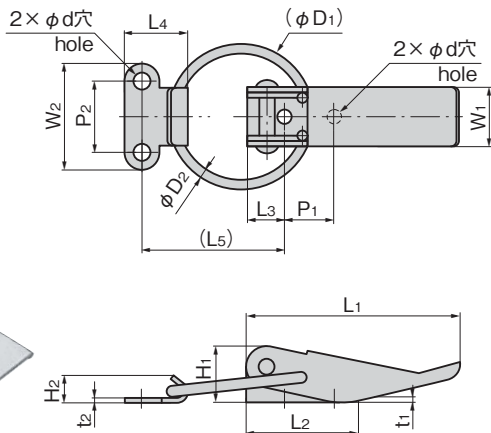

※本図は締り0mmの場合です。
※Drawings show the tightening margin of 0mm.

特徴 Feature

- ばねが強力で振動機器に最適
- ステンレス製で耐食性に優れています。(C-1150)
- Suitable for vibration equipment because a powerful spring is built in.
- Corrosion-resistant stainless steel is used. (C-1150)

仕様

- | | |
|----------|-----------------------------|
| [C-1150] | ●材質：冷間圧延ステンレス鋼板 (SUS304) |
| | ●表面仕上：バレル研磨 |
| [C-150] | ●材質：冷間圧延鋼板 (SPCC) |
| | ●表面仕上：亜鉛めっきクロメート処理 (MFZn-C) |
| 用途 | ●車両関係のボンネット・バッテリーケース・工具箱 |
| 納期 | ●標準在庫品 |

Specifications

- | | |
|--------------|---|
| [C-1150] | ●Material: Cold rolled stainless steel plate (SUS304) |
| | ●Finish: Barrel polishing |
| [C-150] | ●Material: Cold rolled steel plate (SPCC) |
| | ●Finish: Zinc plating chromate treatment (MFZn-C) |
| Specific use | ●Bonnets, battery cases and tool boxes |

※引張荷重は締り0.5mmのときを示します。 ※Tensile load is based on the tightening margin of 0.5mm.

商品番号 Product No.	RoHS 10+	備考 Remarks	L ₁	L ₂	L ₃	L ₄	(L ₅)	W ₁	W ₂	H ₁	H ₂	t ₁	t ₂	P ₁	P ₂	(D ₁)	D ₂	d	引張荷重 N Tensile load	製品質量 (g) Mass	コード Code
C-1150-1	●	SUS	72.5	38	13	22.3	52.5	21	37	19	11	1.5	2	17	25	54	3.5	5.2	50	72	20859
C-1150-2	●		52	29	12	17	38	16	26	15	9	1.5	1.5	13	18	39	3	4.2	36	38	20860
C-1150-3	●		36.5	23	8	16	30	12	23	10	8.5	1	1.5	10	16	27	2	3.2	21	14	20861
C-150-1	●	SPCC	72.5	38	13	22.3	52.5	21	37	19	11	1.6	2.3	17	25	54	3.5	5.2	50	72	20443
C-150-2	●		52	29	12	17	38	16	26	15	9	1.6	1.6	13	18	39	3	4.2	36	38	20444
C-150-3	●		36.5	23	8	16	30	12	23	10	8.5	1	1.6	10	16	27	2	3.2	21	14	20445

●: RoHS10指令対応品 ▲: RoHS10指令に対応可能です。

価格確認

