

**B-1122**  
ステンレス製

**B-122**  
鉄製



ねじ付管筒(丸ボス・溶接ナット)  
TAPPED TUBES

蝶番・ステー・周辺機器



特徴 Feature

- 用途に応じた大きさが選べます。
- Select the various sizes according to your application

仕様	● 材質: B-1122/ステンレス鋼棒(SUS304相当) B-122/軟鋼線材(SWRM) 冷間圧造用炭素鋼線(SWCH) 一般構造用圧延鋼材(SS400相当)
	● 表面仕上: 生地
用途	● 配分電盤・制御盤・ローレットつまみの受け
納期	● 標準在庫品
備考	● 他の寸法も製作します。 ● 角ボスも製作します。

Specifications	● Material: B-1122: Stainless steel bar (SUS304 equivalent) B-122: Soft steel wire (SWRM) Cold heading carbon steel wire (SWCH) Rolled steel for general structure (SS400 equivalent)
	● Finish: Plain
Specific-use	● Power/distribution and control boards and knurl catches

[ B-122-1~13  
B-122-51~71  
B-1122-1~12 ]

[ B-122-21~30 ]

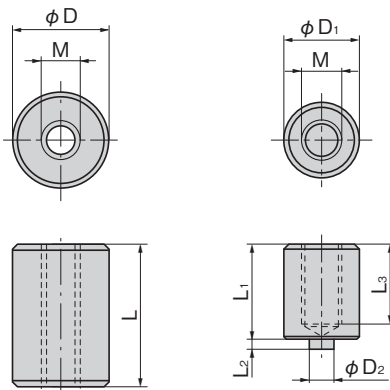

商品番号 Product No.	RoHS 10	材質 Material	M	L	D	製品質量(g) Mass	コード Code
B-1122-1	●	SUS304相当 SUS304 equivalent	M8	30	20	62	12799
B-1122-2	●			30	15	31	12800
B-1122-3	●			20	20	42	12801
B-1122-4	●			20	15	20	12802
B-1122-6	●			15	15	15	11552
B-1122-5	●		M6	20	12	14	11551
B-1122-7	●			15	15	18	11553
B-1122-8	●			10	15	11	11554
B-1122-11	●		M5	10	12	7	12804
B-1122-12	●			15	15	19	12805
B-1122-9	●	M4	10	15	12	11555	
B-1122-10	●		10	15	13	12803	
B-122-56	●	SS400相当 SS400 equivalent	M12	20	20	33	13490
B-122-51	●		M10	30	20	57	13485
B-122-54	●			25	20	47	13488
B-122-57	●	SWCH	M8	20	20	38	13491
B-122-1	●	SWRM		30	20	62	10313
B-122-2	●	SS400相当 SS400 equivalent	M8	30	15	31	10314
B-122-53	●			25	25	88	13487
B-122-55	●	SWCH	M8	25	20	53	13489
B-122-3	●	SWRM		20	20	42	10315
B-122-4	●			20	15	20	10316
B-122-13	●		15	20	31	13288	
B-122-6	●	SS400相当 SS400 equivalent	M6	15	15	15	10318
B-122-52	●			30	15	36	13486
B-122-58	●	SWCH	M6	20	20	46	13492
B-122-59	●			20	15	24	13493
B-122-5	●	SS400相当 SS400 equivalent	M6	20	12	14	10317
B-122-7	●			15	15	18	10319
B-122-64	●	SWCH	M5	15	12	10	13498
B-122-68	●			10	20	23	13502
B-122-8	●	SWRM	M5	10	15	11	10320
B-122-11	●			10	12	7	10323
B-122-60	●	SS400相当 SS400 equivalent	M5	20	15	25	13494
B-122-61	●			20	10	10	13495
B-122-12	●	SS400相当 SS400 equivalent	M5	15	15	19	11532
B-122-65	●			15	12	11	13499
B-122-66	●	SWRM	M5	15	10	7	13500
B-122-9	●			10	15	12	10321
B-122-69	●	SS400相当 SS400 equivalent	M4	10	12	8	13503
B-122-70	●			10	10	5	13504
B-122-62	●	SS400相当 SS400 equivalent	M4	20	10	11	13496
B-122-63	●			15	15	19	13497
B-122-67	●	SWCH	M4	15	10	8	13501
B-122-10	●			10	15	13	10322
B-122-71	●	SWCH	M4	10	10	5	13505

商品番号 Product No.	RoHS 10	材質 Material	M	L <sub>1</sub>	L <sub>2</sub>	L <sub>3</sub>	D <sub>1</sub>	D <sub>2</sub>	製品質量(g) Mass	コード Code
B-122-21	●	SWRM	M8	20	2	15	15	4.9	22	13050
B-122-22	●			15	2	12	15	4.9	17	13051
B-122-23	●		M6	15	2	12	15	4.9	18	13052
B-122-24	●			10	2	8	15	4.9	12	13053
B-122-25	●		M5	15	2	12	12	3.9	11	13054
B-122-27	●			15	1.5	12	10	3.9	7	13056
B-122-26	●			10	2	8	12	3.9	8	13055
B-122-29	●		M4	10	1.5	8	10	3.9	5	13058
B-122-28	●			15	1.5	12	10	3.9	8	13057
B-122-30	●		10	1.5	8	10	3.9	5	13059	

- : RoHS10指令対応品
- ▲: RoHS10指令に対応可能です。

- 長蝶番
- 平蝶番
- 裏蝶番
- 抜差し蝶番
- フリーザーヒンジ
- 特装車蝶番
- クリーンヒンジ
- 特殊蝶番
- トルクヒンジ
- ステー

OTHER B PRODUCTS  
その他のB製品

