

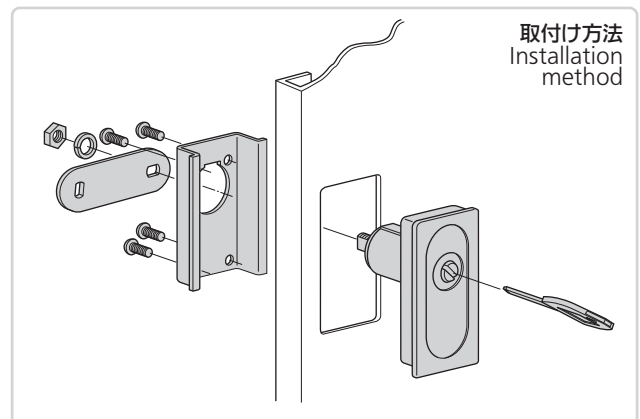

A-419

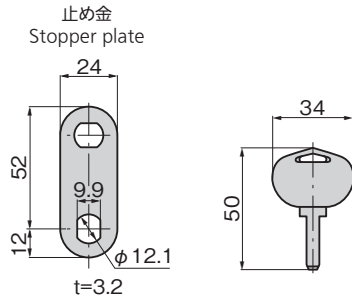

キーNo.00288Z
Key

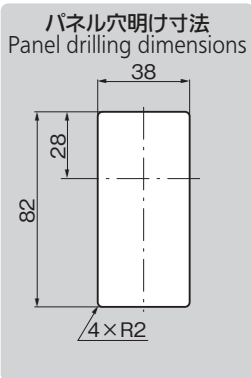
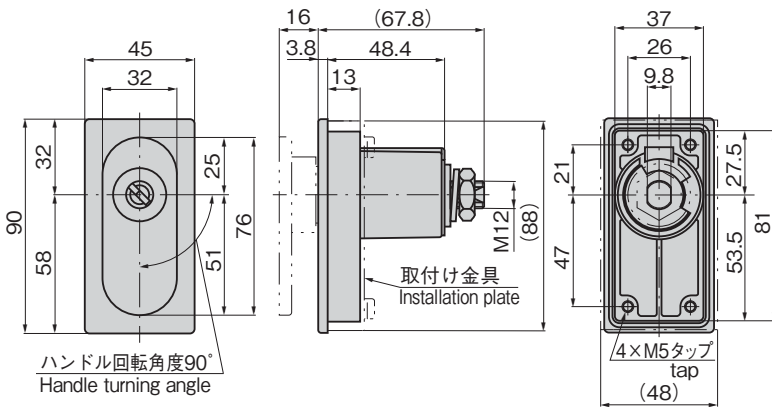

取付け方法
Installation method

特徴 Feature

- 日本自動販売システム機械工業会規格品錠前が組込み可能
- 防水タイプ (Oリング・パッキン使用)
- パネル取付け面からの出張りは4mmの平面タイプ
- 鍵は施錠時のみ抜けるので施錠忘れがありません。
- 標準錠前は、専用薄型シリンダー (C-288-G) を使用
- 左右兼用型 (カムを裏返すと左右の入替えができます。)
- A standard lock approved by Japan Vending System Manufacturers Association can be incorporated.
- Waterproof (using O-ring and packing).
- Flush type. Protrusion from the panel installation surface is 4mm.
- Key can be removed only when locking. Ensure locking without fail.
- Special thin cylinder (C-288-G) is used for standard lock.
- For both left-hand and right-hand use. (the left-hand or right-hand use can be changed by reversing the cam)

仕様	<ul style="list-style-type: none"> ● 材質: 亜鉛合金 (ZDC) ● 表面仕上: クロムめっき (MZCr) ● 鍵番号: 00288Z ● 同一鍵番号・鍵違い・指定番号も製作します。 ● 最大鍵違い数: 17万7,000通り ● 適用板厚: 1.0~3.2mm ● 付属品: キー2本・取付け板・専用止め金・ビスセット
動作	<ol style="list-style-type: none"> 1. 開扉時はキーを右に回し、ポップアップしたハンドルを左(右)に回します。 2. キーは本体から抜けません。 3. 閉扉時はハンドルを元の位置に戻し、押し込み施錠します。
用途	<ul style="list-style-type: none"> ● 自動販売機・環境機器・制御盤
納期	<ul style="list-style-type: none"> ● 標準在庫品

Specifications	<ul style="list-style-type: none"> ● Material: Zinc alloy (ZDC) ● Finish: Chrome plating (MZCr) ● Key No.: 00288Z ● Keyed alike, key differences and your specified No. are available. ● No. of max. key differences: 177,000 ● Applicable panel thickness: 1.0 to 3.2mm ● Accessories: Two keys, installation plate, special stopper plate and screws
Operation	<ol style="list-style-type: none"> 1. To open door turn key clockwise and then popped handle counterclockwise (or clockwise). 2. Key can not be removed from the main body. 3. To close door return popped handle to its original position and press it for locking.
Specific-use	<ul style="list-style-type: none"> ● Vending machines, environment equipment and control boards

商品番号 Product No.	RoHS 10	製品質量 (g) Mass	コード Code
A-419		610	01705

- : RoHS10指令対応品
- ▲ : RoHS10指令に対応可能です。

価格確認

