



特徴 Feature

- 錠前は操作性に優れた防塵シャッター付新型リバーシブルキーTAK60を標準装備(A-45-1-TAK60)
- 左右兼用型
- The lock comes standard with the TAK60, a new-style reversible key with an easy-to-use dustproof shutter.
- (A-45-1-TAK60)
- For both left-hand and right-hand use.

仕様	<ul style="list-style-type: none"> <li>材質: 亜鉛合金 (ZDC)</li> <li>表面仕上: クロムめっき (MZCr)</li> <li>付属品: 大ナット・ビスセット・キー2本</li> </ul>
用途	<ul style="list-style-type: none"> <li>配分電盤・制御盤</li> </ul>
納期	<ul style="list-style-type: none"> <li>標準在庫品</li> </ul>
備考	<ul style="list-style-type: none"> <li>マスターシステム、指定同番、鍵違いも製作します。</li> <li>特別な表面処理はご相談ください。</li> <li>本製品の止め金取付け用ねじは、緩み防止のため「緩み防止剤」の塗布をお奨めします。</li> </ul>

Specifications	<ul style="list-style-type: none"> <li>Material: Zinc alloy (ZDC)</li> <li>Finish: Chrome plating (MZCr)</li> <li>Accessories: Large nut, screws, two keys</li> </ul>
Specific use	<ul style="list-style-type: none"> <li>Power/distribution and control boards</li> </ul>
Remarks	<ul style="list-style-type: none"> <li>It is recommended that thread-locking fluid be used to prevent loosening of the mounting screws for the catch.</li> </ul>



A-45-1-TAK60



キーNo.TAK60  
Key



キーNo.0200  
Key

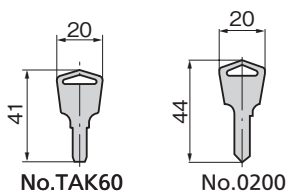
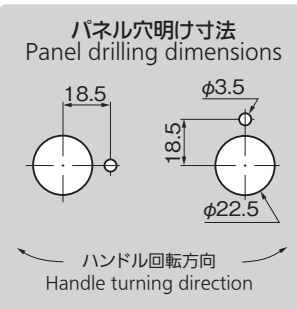
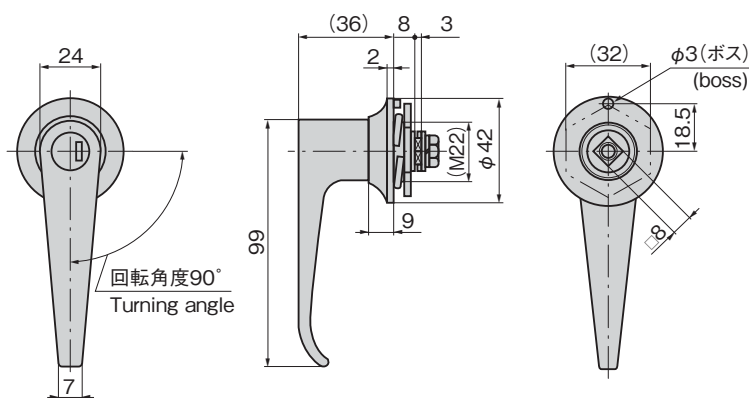

**止め金**  
Stopper plate

止め金は652~656ページの□8穴の中からお選びください。  
Select stopper plate from those starting on page 652 to 656 with □8 hole.

商品番号 Product No.	RoHS 10	鍵番号 Key No.	最大適用板厚 Max. applicable panel thickness	製品質量(g) Mass	コード Code
A-45-1-TAK60	●	TAK60	2	201	04018
A-45-1	●	0200			00166
A-45-2	●	鍵なし Without lock		197	00167

●: RoHS10指令対応品 ▲: RoHS10指令に対応可能です。

価格確認

