

カジリ防止 止め金装備



A-250-A-1-1

A-250-A-2-1



キーNo.0200  
Key

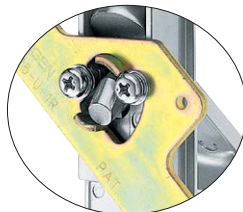

高負荷タイプUベロもあります  
High-load type with U-rims also available  
AC-25-U (656ページ)

商品番号 Product No.	RoHS 10	鍵番号 Key No.	付属止め金 Attached stopper plate	コード Code
A-250-A-1-1	●	0200	AC-25-AB-1N	01773
A-250-A-1-2	●	鍵なし Without lock		01776
A-250-A-2-1	●	0200	AC-25-AB-2N	01774
A-250-A-2-2	●	鍵なし Without lock		01392
A-250-A-3-1	●	0200	AC-25-AB-3N	01775
A-250-A-3-2	●	鍵なし Without lock		01394

特徴 Feature

- 止め金はカジリ防止タイプを標準装備
- パネル穴明け寸法はA-240と同じです。
- 左右兼用型(止め金を裏返すと左右の入替えができます。)
- Anti-seizing type stopper plate is standard.
- Panel drilling dimensions are same as A-240.
- For both left-hand and right-hand use. (The left-hand or right-hand use can be changed by reversing the stopper plate)

仕様	● 材 質: 亜鉛合金 (ZDC) ● 表面仕上: サチライトクロムめっき (MZCr) ● 付 属 品: キー2本・ビスセット・専用止め金
用途	● 配分電盤・制御盤
納期	● 標準在庫品
備考	● 摺動部には潤滑油をご使用ください。特に塗料の付着にはご注意ください。 ● 本製品の錠前はキー先端部での操作となります。 ● 鍵を必要以上に回転させると錠前部・鍵先端部が破損する恐れがありますのでご注意ください。 ● 本製品の止め金取付け用ねじは、緩み防止のため「緩み防止剤」の塗布をお奨めします。

Specifi-cations	● Material: Zinc alloy (ZDC) ● Finish: Satellite chrome plating (MZCr) ● Accessories: Two keys, screws and special stopper plate
Specific use	● Power/distribution and control boards
Remarks	● Use lubrication oil for moving parts. Especially be careful of sticking coating. ● The lock on this product is operated with the tip of the key. ● Note that care is required, since turning the key more than is necessary risks damaging the lock or the tip of the key. ● It is recommended that thread-locking fluid be used to prevent loosening of the mounting screws for the catch.

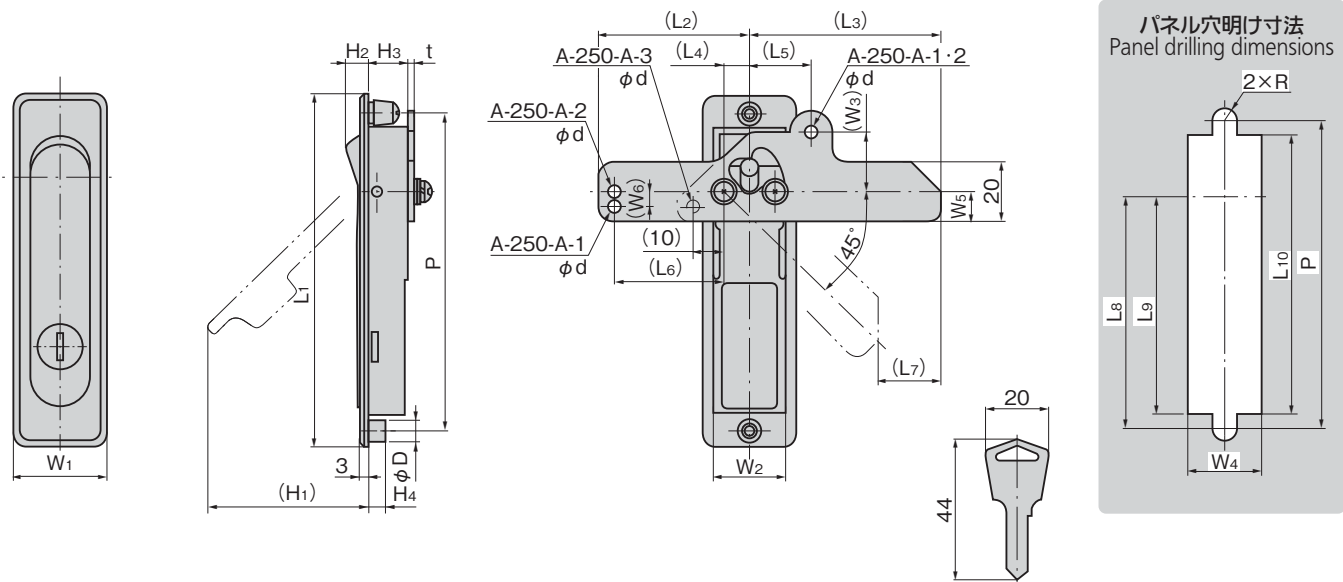

商品番号 Product No.	L1	(L2)	(L3)	(L4)	(L5)	(L6)	(L7)	L8	L9	L10	W1	W2	(W3)	W4	W5	(W6)	(H1)	H2	H3	H4	t	P	D	d	R	適用板厚 Applicable panel thickness	製品質量 (g) Mass
A-250-A-1-1	142	49.5	65.5	9.5	18	34.5	25.5	93	87.5	117	32	26	22	27	15	5	70	10	17	7	3.2	128	8	4.2	4.5	1.0~2.5	360
A-250-A-1-2	117	48.5	61.5	8.5	20	35	20.5	79	74.5	96	30	23	20	24	10	/	58	8	12.5	6	2.3	105	7	4.2	4	1.0~2.5	235
A-250-A-2-1	84	/	61.5	8.5	/	/	20	48	43.5	63	28	23	/	24	9.5	4.5	35	8	12.5	6	2.3	72	7	4.1	4	1.0~2.5	155

●: RoHS10指令対応品 ▲: RoHS10指令に対応可能です。

価格確認

