



A-480-A-1-TAK60

A-480-A-3-TAK60

キーNo.TAK55 Key

キーNo.TAK60 Key

キーNo.R0220 Key

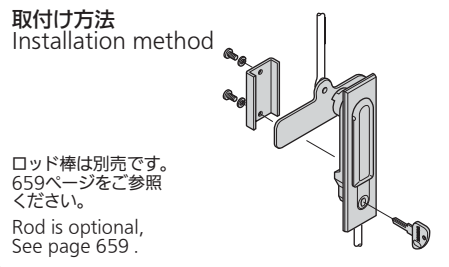
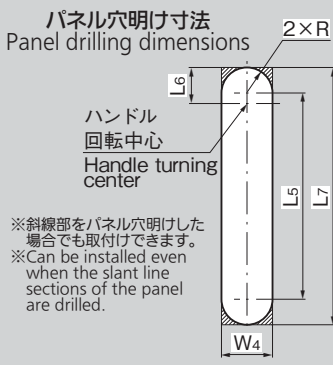
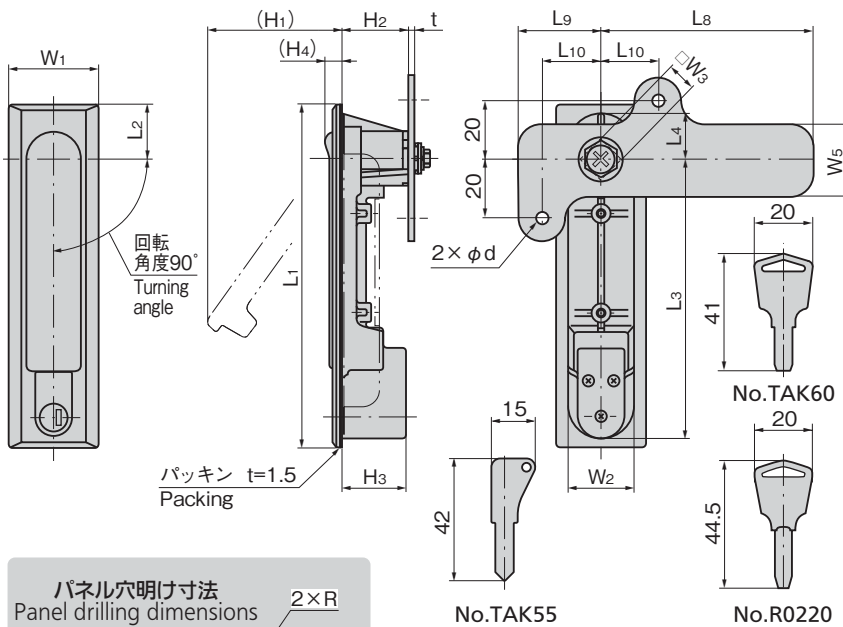

特徴 Feature

- 錠前はディスクを増強し格段とセキュリティアップをしたマルチキーTAK55、操作性に優れたリバーシブルキーTAK60・R0220キーからお選びいただけます。
- ワンタッチ機構(オープン&ロック)
- 錠前は防塵シャッター付
- 防水タイプ(リング・パッキン使用)
- 防水規格IPX5相当(A-480-A-1/A-480-A-2)
- 左右兼用型(カムと止め金を裏返すと左右の入替えができます。)
- Choose a lock from either multi-key TAK55 with an even greater number of disks and bolstered security, or reversible key TAK60 or R0220 key both with excellent ease-of-use.
- One-touch operation mechanism. (Open and lock)
- Lock has dustproof shutter.
- Waterproof. (Using O-ring and packing)
- This product is equivalent for waterproof standard IPX5. (A-480-A-1/A-480-A-2)
- For both left-hand and right-hand use. (The left-hand or right-hand use can be changed by reversing the cam and stopper plate)

仕様

- 材質: アルミニウム合金(ADC)
- 表面仕上: 焼付塗装
- 標準色: ブラック
- 付属品: キー2本・ビスセット・止め金・取付け板・回転方向シール
- 適用板厚: 0.6~2.3mm (A-480-A-1・2) 0.6~3.2mm (A-480-A-3)

用途

- 大型キュービクル・ロッド棒を併用する大型扉
- 標準在庫品

納期

- マスターシステム、指定同番、鍵違いも製作します。

備考

- A-480-A-1・A-2は取付けねじを(M5×14SW)に変更することにより3.2mmまでの板厚に対応することができます。
- 解錠時、レバーが勢い良く開きますのでご注意ください。
- 本製品の止め金取付け用ねじは、緩み防止のため「緩み防止剤」の塗布をお奨めします。

Specifications

- Material: Aluminum alloy (ADC)
- Finish: Baked
- Standard color: Black
- Accessories: Two keys, screws, stopper plate and installation plate, turning direction sticker
- Applicable panel thickness: 0.6~2.3mm (A-480-A-1・2) 0.6~3.2mm (A-480-A-3)

Specific-use

- Large cubicles, large doors using rod and vibration equipment doors

Remarks

- A-480-A-1/A-2 can be adapted to max. panel thickness of up to 3.2mm by replacing the screws with M5 X 14SW.
- Take care when releasing the lock, as the lever springs open with some force.
- It is recommended that thread-locking fluid be used to prevent loosening of the mounting screws for the catch.

商品番号 Product No.	RoHS 10	鍵番号 Key No.	保護等級 Protection class	L1	L2	L3	L4	L5	L6	L7	L8	L9	L10	W1	W2	W3	W4	W5	(H1)	H2	H3	(H4)	d	t	R	付属止め金 Attached stopper plate	製品質量(g) Mass	コード Code
A-480-A-1-TAK55	●	TAK55	IPX5																									04897
A-480-A-1-TAK60	●	TAK60	IPX5	190	30	155	25	145	25.5	181				48	35		36		73			12	3.2	18	AC-25-E-1	685	04047	
A-480-A-1	●	R0220	IPX5								72	28	20			10		25	35.5	34.5		4.5					00952	
A-480-A-2-TAK55	●	TAK55	IPX5																								04898	
A-480-A-2-TAK60	●	TAK60	IPX5	160	20	136	15.5	121	16	153				40	31		32							16	AC-25-E-2	590	04048	
A-480-A-2	●	R0220	IPX5																								01088	
A-480-A-3-TAK55	●	TAK55																	60			11	2.3				04899	
A-480-A-3-TAK60	●	TAK60		142	17	121	13	108	13.5	135	62	22	15	32	26	8	27	24		34.5	32.5		4.2	13.5	AC-25-E-4	480	04049	
A-480-A-3	●	R0220																									01089	

●: RoHS10指令対応品 ▲: RoHS10指令に対応可能です。

価格確認

